

Outside diameter	Thickness
D	T

10

JIS

JIS

D PF

Solid Round Dies for Parallel Pipe Threads



Specification



For icon explanation, refer to icon-1

■ Solid round dies for PF external threads with improved die runout accuracy.

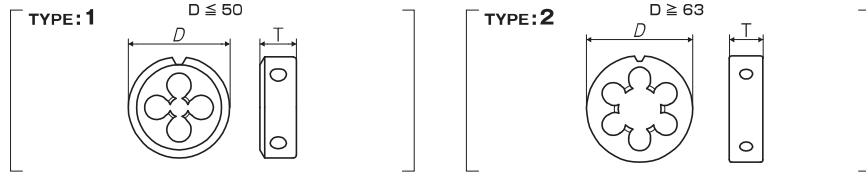

Segment : 3G

Size	Code	D (mm)	T (mm)	Clearance holes	TYPE	MSRP
For PF Threads						
PF1/16-28	TYGPF010NEBC	25	9	4	1	¥ 9,350 [※]
PF1/8-28	TYGPF020NEBC	25	9	5	1	¥ 9,350 [※]
PF1/8-28	TYJPF020NEBC	38	13	4	1	¥ 9,720
PF1/4-19	TYJPF040NEBC	38	13	5	1	¥ 9,720
PF3/8-19	TYJPF060NEBC	38	13	6	1	¥ 9,720 [※]
PF3/8-19	TYMPF060NEBC	50	16	5	1	¥ 15,900
PF1/2-14	TYMPF080NEBC	50	16	5	1	¥ 15,900
PF5/8-14	TYMPF100NEBC	50	16	6	1	¥ 17,900 [※]
PF3/4-14	TYMPF120NEBC	50	16	6	1	¥ 15,900 [※]
PF3/4-14	TYRPF120NEBC	63	20	6	2	¥ 45,800
PF1 -11	TYUPF160NEBC	75	25	6	2	¥ 78,400
PF1 1/4-11	TYUPF200NEBC	75	25	8	2	¥ 78,400 [※]
PF1 1/2-11	TYUPF240NEBC	75	25	8	2	¥ 78,400 [※]
PF2 -11	TYYPF320NEBC	105	30	8	2	¥188,000 [※]

* Adjustable dies (AR-D) and dies manufactured from SKS material have been discontinued as a result of orders received in December 2013. For this product, please check "2013 - 2014 General Catalog".

Spiral Fluted Taps (for blind hole) ①

Spiral Fluted Taps (for through hole) ②

Spiral Pointed Taps (for through hole) ③

Hand Taps ④

Cemented Carbide Taps ⑤

Roll Taps ⑥

Special Thread Taps (Single Inspection Tools) ⑦

Pipe Taps ⑧

Thread Mills ⑨

Dies ⑩

Center Drills Centering Tools ⑪

JIS

10-26

10 Dies

Outside diameter	Thickness
D	T

JIS

JIS

D PF LH

Solid Round Dies for Parallel Pipe Threads, for Left Hand Threads



Specification



For icon explanation, refer to icon-1

■ Solid round dies for external PF left hand threads with improved runout accuracy.

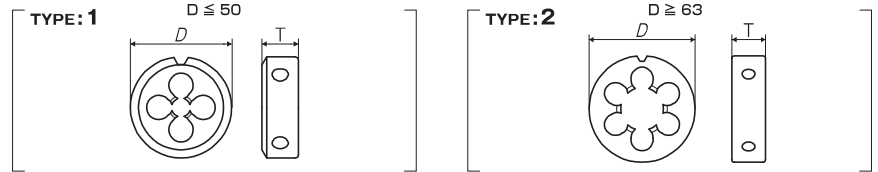

Segment : 3G

Size	Code	D (mm)	T (mm)	Clearance holes	TYPE	MSRP
For PF Threads						
PF1/8-28	GYJPF020NEBC	38	13	4	1	¥ 14,600 [※]
PF1/4-19	GYJPF040NEBC	38	13	5	1	¥ 14,600 [※]
PF3/8-19	GYMPF060NEBC	50	16	5	1	¥ 23,900 [※]
PF1/2-14	GYMPF080NEBC	50	16	5	1	¥ 23,900 [※]
PF3/4-14	GYRPF120NEBC	63	20	6	2	¥ 68,700 [※]
PF1 -11	GYUPF160NEBC	75	25	6	2	¥118,000 [※]

* Adjustable dies (AR-D) and dies manufactured from SKS material have been discontinued as a result of orders received in December 2013. For this product, please check "2013 - 2014 General Catalog".

Spiral Fluted Taps (for blind hole) ①

Spiral Fluted Taps (for through hole) ②

Spiral Pointed Taps (for through hole) ③

Hand Taps ④

Cemented Carbide Taps ⑤

Roll Taps ⑥

Special Thread Taps (Single Inspection Tools) ⑦

Pipe Taps ⑧

Thread Mills ⑨

Dies ⑩

Center Drills Centering Tools ⑪

JIS

10-27

JIS

D NPSM

Solid Round Dies for American Parallel Pipe Threads

Specification



For icon explanation, refer to icon-1

■The D NPSM is a solid round dies for parallel external thread processing of American tapered pipe threads that have improved die runout accuracy.



Outside diameter	Thickness
D	T

10

JIS

Spiral Fluted Taps (for blind hole) ①

Spiral Fluted Taps (for through hole) ②

Spiral Pointed Taps (for through hole) ③

Hand Taps ④

Cemented Carbide Taps ⑤

Roll Taps ⑥

Special Thread Taps (Simple Inspection Tools) ⑦

Pipe Taps ⑧

Thread Mills ⑨

Dies ⑩

Center Drills (Centering Tools) ⑪

JIS

10-28

10 Dies

JIS

JIS

D PT

Solid Round Dies for Taper Pipe Threads

Specification



For icon explanation, refer to icon-1

■The D PT is a solid round dies for PT external tapered pipe thread processing with improved runout accuracy.



Outside diameter	Thickness	Position of basic dia.
D	T	lg

TYPE: 1

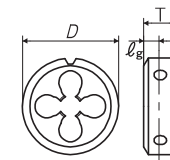

TYPE: 2

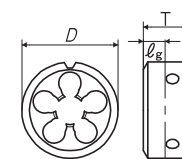

TYPE: 3

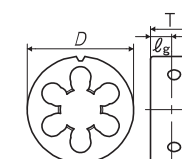

Segment : 3G

Size	Code	D (mm)	T (mm)	lg (mm)	Clearance holes	TYPE	MSRP
For PT Threads							
PT1/16-28	TYJPT010NEBC	38	13	6	4	1	¥ 14,100*
PT1/8-28	TYJPT020NEBC	38	13	6	4	1	¥ 14,100
PT1/4-19	TYJPT040NEBC	38	18	8.5	5	2	¥ 14,100
PT3/8-19	TYMPT060NEBC	50	22	10	5	2	¥ 22,600
PT1/2-14	TYMPT080NEBC	50	22	12	6	2	¥ 22,600
PT5/8-14	TYRPT100NEBC	63	24	12	6	3	¥ 66,900*
PT3/4-14	TYRPT120NEBC	63	24	12.5	6	3	¥ 59,300
PT7/8-14	TYUPT140NEBC	75	30	12.5	6	3	¥120,000*
PT1 -11	TYUPT160NEBC	75	30	15	6	3	¥105,000
PT1 1/4-11	TYUPT200NEBC	75	30	15	6	3	¥105,000*
PT1 1/2-11	TYUPT240NEBC	75	30	15	6	3	¥105,000*
PT2 -11	TYYPT320NEBC	105	36	17.5	8	3	¥255,000*

*Adjustable dies (AR-D) and dies manufactured from SKS material have been discontinued as a result of orders received in December 2013. For this product, please check "2013 - 2014 General Catalog".

JIS

10-29

TYPE: 1

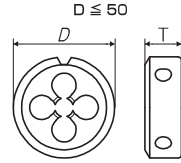

TYPE: 2

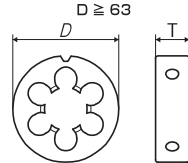

Segment : 3G

Size	Code	D (mm)	T (mm)	Clearance holes	TYPE	MSRP
For NPSM Threads						
1/16-27 NPSM	TYJSM010NEBC	38	13	4	1	¥ 11,400*
1/8-27 NPSM	TYJSM020NEBC	38	13	4	1	¥ 11,400*
1/4-18 NPSM	TYJSM040NEBC	38	13	5	1	¥ 11,400*
3/8-18 NPSM	TYMSM060NEBC	50	16	5	1	¥ 18,200*
1/2-14 NPSM	TYMSM080NEBC	50	16	5	1	¥ 18,200*
3/4-14 NPSM	TYRSM120NEBC	63	20	6	2	¥ 52,200*
1 -11.5 NPSM	TYUSM160NEBC	75	25	6	2	¥ 89,800*
1 1/4-11.5 NPSM	TYUSM200NEBC	75	25	8	2	¥ 89,800*

*Adjustable dies (AR-D) and dies manufactured from SKS material have been discontinued as a result of orders received in December 2013. For this product, please check "2013 - 2014 General Catalog".

* = Specified Distribution Items, Made to order products. For improvement, spec may change without advance notice.



* = Specified Distribution Items, Made to order products. For improvement, spec may change without advance notice.

JIS

D PT LH

Solid Round Dies for Taper Pipe Threads, for Left Hand Threads

Specification



For icon explanation, refer to icon-1

■ The D PT LH are solid round dies for left hand external PT tapered pipe threads that have improved die runout accuracy.

Outside diameter	Thickness	Position of basic dia.
D	T	lg

10

JIS



Spiral Fluted Taps (for blind hole) ①

Spiral Fluted Taps (for through hole) ②

Spiral Pointed Taps (for through hole) ③

Hand Taps ④

Cemented Carbide Taps ⑤

Roll Taps ⑥

Special Thread Taps (Simple Inspection Tools) ⑦

Pipe Taps ⑧

Thread Mills ⑨

Dies ⑩

Center Drills (Centering Tools) ⑪

JIS 10-30

10 Dies

JIS

JIS

D NPT

Solid Round Dies for American Taper Pipe Threads

Specification



For icon explanation, refer to icon-1

■ The D NPT are solid round dies for American external tapered pipe threads with improved runout accuracy.

Outside diameter	Thickness	Position of basic dia.
D	T	lg



Spiral Fluted Taps (for blind hole) ①

Spiral Fluted Taps (for through hole) ②

Spiral Pointed Taps (for through hole) ③

Hand Taps ④

Cemented Carbide Taps ⑤

Roll Taps ⑥

Special Thread Taps (Simple Inspection Tools) ⑦

Pipe Taps ⑧

Thread Mills ⑨

Dies ⑩

Center Drills (Centering Tools) ⑪

JIS 10-31

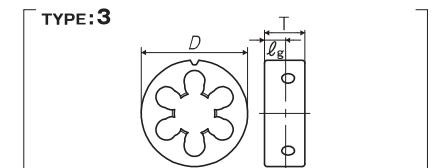
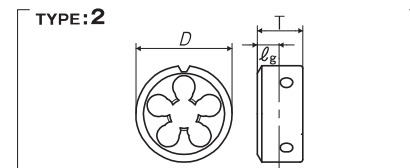
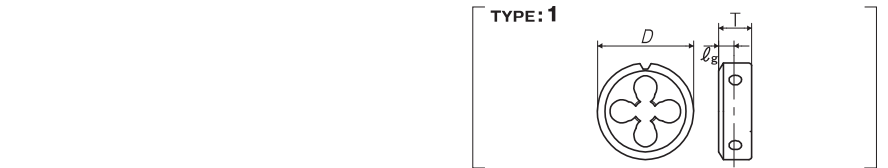
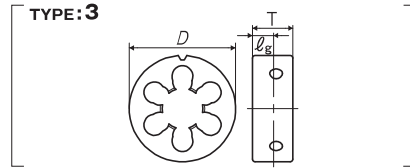
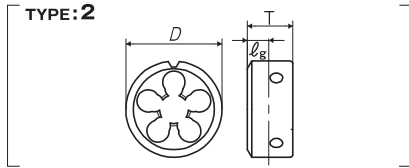
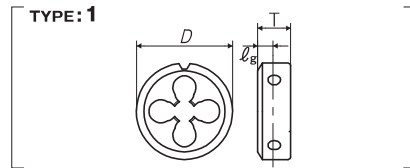

Segment: 3G

Size	Code	D (mm)	T (mm)	lg (mm)	Clearance holes	TYPE	MSRP
For PT Threads							
PT1/8-28	GYJPT020NEBC	38	13	6	4	1	¥ 21,200*
PT1/4-19	GYJPT040NEBC	38	18	8.5	5	2	¥ 21,200*
PT3/8-19	GYMPT060NEBC	50	22	10	5	2	¥ 33,900*
PT1/2-14	GYMPT080NEBC	50	22	12	6	2	¥ 33,900*
PT3/4-14	GYRPT120NEBC	63	24	12.5	6	3	¥ 89,000*
PT1-11	GYUPT160NEBC	75	30	15	6	3	¥ 158,000*

* Adjustable dies (AR-D) and dies manufactured from SKS material have been discontinued as a result of orders received in December 2013. For this product, please check "2013 - 2014 General Catalog".

Segment: 3G

Size	Code	D (mm)	T (mm)	lg (mm)	Clearance holes	TYPE	MSRP
For NPT Threads							
1/16-27 NPT	TYJNT010NEBC	38	13	5	4	1	¥ 16,800*
1/8-27 NPT	TYJNT020NEBC	38	13	5	4	1	¥ 16,800
1/4-18 NPT	TYJNT040NEBC	38	18	8	5	2	¥ 16,800
3/8-18 NPT	TYMNT060NEBC	50	22	8	5	2	¥ 27,100*
1/2-14 NPT	TYMNT080NEBC	50	22	10	6	2	¥ 27,100*
3/4-14 NPT	TYRNT120NEBC	63	24	10	6	3	¥ 70,900*
1-11.5 NPT	TYUNT160NEBC	75	30	13	6	3	¥ 126,000*
1 1/4-11.5 NPT	TYUNT200NEBC	75	30	13.5	6	3	¥ 126,000*

* Adjustable dies (AR-D) and dies manufactured from SKS material have been discontinued as a result of orders received in December 2013. For this product, please check "2013 - 2014 General Catalog".

D NPTF

Solid Round Dies for American Dryseal Taper Pipe Threads

Outside diameter	Thickness	Position of basic dia.
D	T	lg



Specification



For icon explanation, refer to icon-1

■ The D NPTF are solid round dies for the American dryseal external tapered pipe threads for dry sealed tubes with improved runout accuracy.

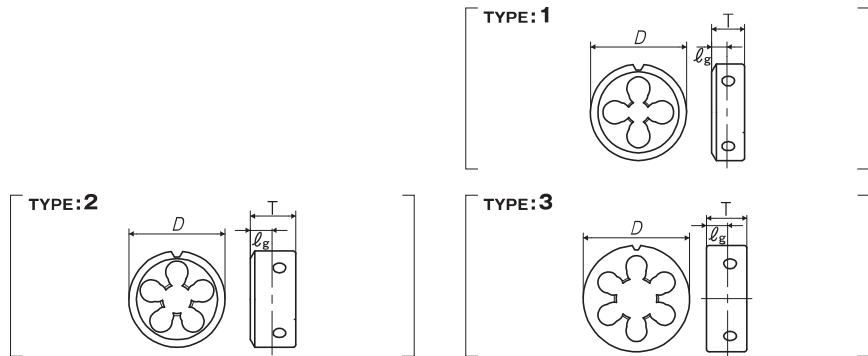

Segment: 3G

Size	Code	D (mm)	T (mm)	lg (mm)	Clearance holes	TYPE	MSRP
For NPTF Threads							
1/16-27 NPTF	TYJNF01ONEBC	38	13	6	4	1	¥ 18,400*
1/8-27 NPTF	TYJNF02ONEBC	38	13	6	4	1	¥ 18,400*
1/4-18 NPTF	TYJNF04ONEBC	38	18	10	5	2	¥ 18,400*
3/8-18 NPTF	TYMNF06ONEBC	50	22	10	5	2	¥ 29,700*
1/2-14 NPTF	TYMNF08ONEBC	50	22	12	6	2	¥ 29,700*
3/4-14 NPTF	TYRNF12ONEBC	63	24	12	6	3	¥ 78,200*
1-11.5 NPTF	TYUNF16ONEBC	75	30	15	6	3	¥ 140,000*
1 1/4-11.5 NPTF	TYUNF20ONEBC	75	30	15.5	6	3	¥ 140,000*

* Adjustable dies (AR-D) and dies manufactured from SKS material have been discontinued as a result of orders received in December 2013. For this product, please check "2013 - 2014 General Catalog".

10

JIS

Spiral Fluted Taps (for blind hole) ①

Spiral Fluted Taps (for through hole) ②

Spiral Pointed Taps (for through hole) ③

Hand Taps ④

Cemented Carbide Taps ⑤

Roll Taps ⑥

Special Thread Taps (single inspection tools) ⑦

Pipe Taps ⑧

Thread Mills ⑨

Dies ⑩

Center Drills Centering Tools ⑪

JIS

10-32