

### 3 Spiral Pointed Tap Series for through hole

Overall length	Thread length	Thread + Neck length	Shank length	Shank dia.	Size of square	Length of square
L	l	ln	ls	Ds	K	lk



## PO

### Spiral Pointed Taps

#### Specification



#### Recommended Tapping Speeds depending on Materials

Medium carbon steels 中炭素鋼	High carbon steels 高炭素鋼
5~10 (m/min)	5~10 (m/min)

For icon explanation, refer to icon-1

#### Product features

- The chips from the tap's cutting chamfer are pushed forward. This is optimal for through hole tapping where there are no obstructions created by the chip.
- Straight flutes are shallow so the taps strength is very high.

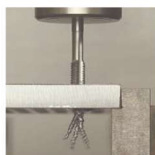

Chips discharge of a PO tap

#### Comparison of a PO and +PO tap

**PO** For low-speed machining on drilling machines and CNC machining centers

Standard tap series PO for through holes.

Old Name	New Name	Size Range
N-PO	PO	M1.2~M50

The PO and +PO use similar wording but have different meanings.

**+PO** For CNC Machining center at medium speed machining. Synchronous feed is recommended.

Plus series +PO for through holes.

Old Name	New Name	Size Range
N+PO	+PO	M3~M6

The PO and +PO use similar wording but have different meanings.

\* Both are general-purpose spiral point taps developed for the processing environment of our customers.

#### Application chart

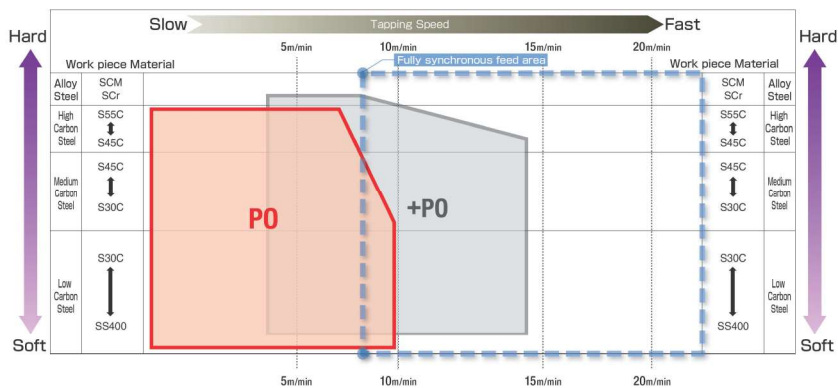

It is an image diagram of a processable range.

Overall length	Thread length	Thread + Neck length	Shank length	Shank dia.	Size of square	Length of square
L	l	ln	ls	Ds	K	lk

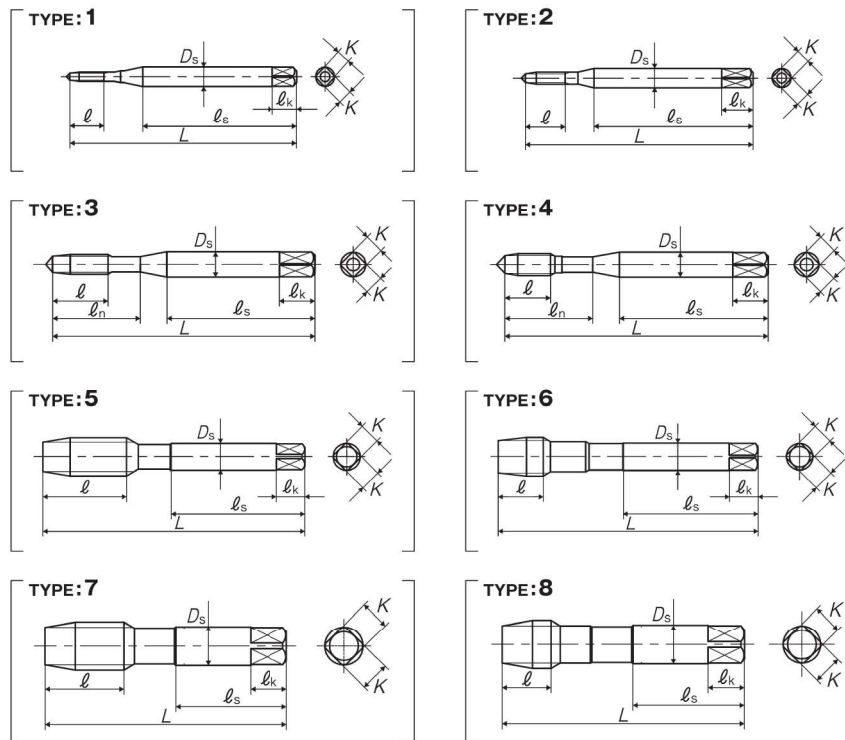

JIS

1

Spiral Fluted Taps  
(for blind hole)

2

Spiral Fluted Taps  
(for through hole)

3

Spiral Pointed Taps  
(for through hole)

4

Hand Taps

5

Cemented  
Carbide Taps

6

Roll Taps

7

Special Thread Taps  
Simple Inspection Tools

8

Pipe Taps

9

Thread Mills

10

Dies

11

Center Drills  
Centering Tools

JIS

3-11

3

JIS

1

Spiral Fluted Taps  
(for blind hole)

2

Spiral Fluted Taps  
(for through hole)

3

Spiral Pointed Taps  
(for through hole)

4

Hand Taps

5

Cemented  
Carbide Taps

6

Roll Taps

7

Special Thread Taps  
Simple Inspection Tools

8

Pipe Taps

9

Thread Mills

10

Dies

11

Center Drills  
Centering Tools

JIS

3-12

### 3 Spiral Pointed Tap Series for through hole

Overall length	Thread length	Thread + Neck length	Shank length	Shank dia.	Size of square	Length of square
L	ℓ	ℓn	ℓs	Ds	K	ℓk

JIS

#### PO Spiral Pointed Taps

Segment : 1E

Size	Class	Code	Chamfer	L (mm)	ℓ (mm)	ℓn (mm)	ℓs (mm)	Ds (mm)	K (mm)	ℓk (mm)	No. of flutes	TYPE	MSRP
For Metric Threads													
M1.2 × 0.25	P1	POP1.2B	5P	36	4.5	-	24	3	2.5	5	2	1	¥ 3,450
M1.4 × 0.3	P1	POP1.4C	5P	36	5.4	-	24	3	2.5	5	2	1	¥ 2,820
M1.4 × 0.3	P2	POQ1.4C	5P	36	5.4	-	24	3	2.5	5	2	1	¥ 2,820
M1.4 × 0.3	P3	POR1.4C	5P	36	5.4	-	24	3	2.5	5	2	1	¥ 2,820*
M1.6 × 0.35	P2	POQ1.6D	5P	36	6.3	-	24	3	2.5	5	2	2	¥ 2,690
M1.6 × 0.35	P3	POR1.6D	5P	36	6.3	-	24	3	2.5	5	2	2	¥ 2,690*
M1.7 × 0.35	P2	POQ1.7D	5P	36	6.3	-	24	3	2.5	5	2	2	¥ 2,690
M1.7 × 0.35	P3	POR1.7D	5P	36	6.3	-	24	3	2.5	5	2	2	¥ 2,690*
M1.7 × 0.35	P4	POS1.7D	5P	36	6.3	-	24	3	2.5	5	2	2	¥ 2,690*
M1.8 × 0.35	P2	POQ1.8D	5P	42	6.3	-	27	3	2.5	5	2	2	¥ 2,690*
M2 × 0.4	P2	POQ2.0E	5P	42	7.2	12	27	3	2.5	5	3	3	¥ 2,150
M2 × 0.4	P3	POR2.0E	5P	42	7.2	12	27	3	2.5	5	3	3	¥ 2,150
M2 × 0.4	P4	POS2.0E	5P	42	7.2	12	27	3	2.5	5	3	3	¥ 2,150
M2 × 0.25	P1	POP2.0B	5P	42	4.5	12	27	3	2.5	5	3	4	¥ 3,300*
M2.2 × 0.45	P2	POQ2.2F	5P	42	8.1	12	27	3	2.5	5	3	3	¥ 1,960
M2.2 × 0.25	P2	POQ2.2B	5P	42	4.5	12	27	3	2.5	5	3	4	¥ 3,300*
M2.3 × 0.4	P2	POQ2.3E	5P	42	7.2	12	27	3	2.5	5	3	3	¥ 1,960
M2.3 × 0.4	P3	POR2.3E	5P	42	7.2	12	27	3	2.5	5	3	3	¥ 1,960*
M2.3 × 0.4	P4	POS2.3E	5P	42	7.2	12	27	3	2.5	5	3	3	¥ 1,960*
M2.5 × 0.45	P2	POQ2.5F	5P	46	8.1	14	29	3	2.5	5	3	3	¥ 1,650
M2.5 × 0.45	P3	POR2.5F	5P	46	8.1	14	29	3	2.5	5	3	3	¥ 1,650*
M2.5 × 0.45	P4	POS2.5F	5P	46	8.1	14	29	3	2.5	5	3	3	¥ 1,650*
M2.5 × 0.35	P2	POQ2.5D	5P	46	6.3	14	29	3	2.5	5	3	4	¥ 2,430*
M2.6 × 0.45	P2	POQ2.6F	5P	46	8.1	14	29	3	2.5	5	3	3	¥ 1,650
M2.6 × 0.45	P3	POR2.6F	5P	46	8.1	14	29	3	2.5	5	3	3	¥ 1,650*
M2.6 × 0.45	P4	POS2.6F	5P	46	8.1	14	29	3	2.5	5	3	3	¥ 1,650*
M2.6 × 0.35	P2	POQ2.6D	5P	46	6.3	14	29	3	2.5	5	3	4	¥ 2,430*
M3 × 0.5	P2	POQ3.0G	5P	46	9	14	26	4	3.2	6	3	3	¥ 1,150
M3 × 0.5	P3	POR3.0G	5P	46	9	14	26	4	3.2	6	3	3	¥ 1,150*
M3 × 0.5	P4	POS3.0G	5P	46	9	14	26	4	3.2	6	3	3	¥ 1,150*
3M0.6	P2	POQ3.0H	5P	46	9	14	26	4	3.2	6	3	3	¥ 1,150*
M3 × 0.35	P2	POQ3.0D	5P	46	6.5	14	26	4	3.2	6	3	4	¥ 1,970*
M3.5 × 0.6	P2	POQ3.5H	5P	52	11	16	29	5	4	7	3	3	¥ 1,150
M3.5 × 0.6	P3	POR3.5H	5P	52	11	16	29	5	4	7	3	3	¥ 1,150*
M3.5 × 0.6	P4	POS3.5H	5P	52	11	16	29	5	4	7	3	3	¥ 1,150*
M3.5 × 0.35	P2	POQ3.5D	5P	52	6.5	16	29	5	4	7	3	4	¥ 1,970*
M4 × 0.7	P2	POQ4.0I	5P	52	11	17	29	5	4	7	3	3	¥ 1,150
M4 × 0.7	P3	POR4.0I	5P	52	11	17	29	5	4	7	3	3	¥ 1,150
M4 × 0.7	P4	POS4.0I	5P	52	11	17	29	5	4	7	3	3	¥ 1,150
4M0.75	P2	POQ4.0J	5P	52	11	17	29	5	4	7	3	3	¥ 1,150*
M4 × 0.5	P2	POQ4.0G	5P	52	9	17	29	5	4	7	3	4	¥ 1,690
M4.5 × 0.75	P2	POQ4.5J	5P	60	13	21	33	5.5	4.5	7	3	3	¥ 1,160*
M4.5 × 0.5	P2	POQ4.5G	5P	60	9	21	33	5.5	4.5	7	3	4	¥ 1,690*
M5 × 0.8	P2	POQ5.0K	5P	60	13	22	33	5.5	4.5	7	3	3	¥ 1,160
M5 × 0.8	P3	POR5.0K	5P	60	13	22	33	5.5	4.5	7	3	3	¥ 1,160
M5 × 0.8	P4	POS5.0K	5P	60	13	22	33	5.5	4.5	7	3	3	¥ 1,160
5M0.9	P2	POQ5.0L	5P	60	13	22	33	5.5	4.5	7	3	3	¥ 1,160*
M5 × 0.5	P2	POQ5.0G	5P	60	9	22	33	5.5	4.5	7	3	4	¥ 1,690

JIS



\* = Specified Distribution Items. Made to order products. For improvement, spec may change without advance notice.

Overall length	Thread length	Thread + Neck length	Shank length	Shank dia.	Size of square	Length of square
L	ℓ	ℓn	ℓs	Ds	K	ℓk

### 3

JIS

#### PO Spiral Pointed Taps

Size	Class	Code	Chamfer	L (mm)	ℓ (mm)	ℓn (mm)	ℓs (mm)	Ds (mm)	K (mm)	ℓk (mm)	No. of flutes	TYPE	MSRP
M5.5 × 0.9	P2	POQ5.5L	5P	62	15	26	33	6	4.5	7	3	3	¥ 1,280*
M5.5 × 0.5	P2	POQ5.5G	5P	62	9	26	33	6	4.5	7	3	4	¥ 1,800*
M6 × 1	P2	POQ6.0M	5P	62	15	26	33	6	4.5	7	3	3	¥ 1,280
M6 × 1	P3	POR6.0M	5P	62	15	26	33	6	4.5	7	3	3	¥ 1,280*
M6 × 1	P4	POS6.0M	5P	62	15	26	33	6	4.5	7	3	3	¥ 1,280
M6 × 0.75	P2	POQ6.0J	5P	62	15	26	33	6	4.5	7	3	3	¥ 1,800
M6 × 0.75	P3	POR6.0J	5P	62	15	26	33	6	4.5	7	3	3	¥ 1,800*
M6 × 0.5	P2	POQ6.0G	5P	62	9	26	33	6	4.5	7	3	4	¥ 1,800*
M7 × 1	P2	POQ7.0M	5P	70	19	-	36	6.2	5	8	3	5	¥ 1,560
M7 × 1	P3	POR7.0M	5P	70	19	-	36	6.2	5	8	3	5	¥ 1,560*
M7 × 0.75	P2	POQ7.0J	5P	70	19	-	36	6.2	5	8	3	5	¥ 2,300*
M7 × 0.75	P3	POR7.0J	5P	70	19	-	36	6.2	5	8	3	5	¥ 2,300*
M7 × 0.5	P2	POQ7.0G	5P	70	10	-	36	6.2	5	8	3	6	¥ 2,870*
M8 × 1.25	P3	POR8.0N	5P	70	19	-	36	6.2	5	8	3	5	¥ 1,790
M8 × 1.25	P4	POS8.0N	5P	70	19	-	36	6.2	5	8	3	5	¥ 1,790
M8 × 1	P3	POR8.0M	5P	70	19	-	36	6.2	5	8	3	5	¥ 2,030
M8 × 1	P4	POS8.0M	5P	70	19	-	36	6.2	5	8	3	5	¥ 2,030*
M8 × 0.75	P3	POR8.0J	5P	70	19	-	36	6.2	5	8	3	5	¥ 2,300*
M8 × 0.5	P2	POQ8.0G	5P	70	10	-	36	6.2	5	8	3	6	¥ 2,870*
M9 × 1.25	P3	POR9.0N	5P	75	23	-	38	7	5.5	8	3	5	¥ 2,280*
M9 × 1	P3	POR9.0M	5P	75	23	-	38	7	5.5	8	3	5	¥ 2,710*
M9 × 0.75	P3	POR9.0J	5P	75	13	-	38	7	5.5	8	3	6	¥ 3,290*
M9 × 0.5	P2	POQ9.0G	5P	75	11	-	38	7	5.5	8	3	6	¥ 3,580*
M10 × 1.5	P3	POR10.0N	5P	75	23	-	38	7	5.5	8	3	5	¥ 2,280
M10 × 1.5	P4	POS10.0N	5P	75	23	-	38	7	5.5	8	3	5	¥ 2,280
M10 × 1.25	P3	POR10.0M	5P	75	23	-	38	7	5.5	8	3	5	¥ 2,280*
M10 × 1.25	P4	POS10.0M	5P	75	23	-	38	7	5.5	8	3	5	¥ 2,280*
M10 × 1	P3	POR10.0M	5P	75	23	-	38	7	5.5	8	3	5	¥ 2,710
M10 × 1	P4	POS10.0M	5P	75	23	-	38	7	5.5	8	3	5	¥ 2,710*
M10 × 0.75	P3	POR10.0J	5P	75	13	-	38	7	5.5	8	3	6	¥ 3,290*
M10 × 0.5	P2	POQ10.0G	5P	75	11	-	38	7	5.5	8	3	6	¥ 3,580*
M11 × 1.25	P3	POR11.0N	5P	82	26	-	42	8.5	6.5	9	3	5	¥ 3,230*
M11 × 1	P3	POR11.0M	5P	82	26	-	42	8.5	6.5	9	3	5	¥ 3,800*
M11 × 0.75	P3	POR11.0J	5P	82	14	-	42	8.5	6.5	9	3	6	¥ 4,850*
M11 × 0.5	P2	POQ11.0G	5P	82	12	-	42	8.5	6.5	9	3	6	¥ 4,850*
M12 × 1.75	P4	POS12.0P	5P	82	26	-	42	8.5	6.5	9	3	5	¥ 3,230
M12 × 1.75	P5	POT12.0P	5P	82	26	-	42	8.5	6.5	9	3	5	¥ 3,230*
M12 × 1.75	P6	POU12.0P	5P	82	26	-	42	8.5	6.5	9	3	5	¥ 3,230*
M12 × 1.5	P3	POR12.0M	5P	82	26	-	42	8.5	6.5	9	3	5	¥ 3,230*
M12 × 1.5	P4	POS12.0M	5P	82									

### 3 Spiral Pointed Tap Series for through hole

Overall length	Thread length	Thread + Neck length	Shank length	Shank dia.	Size of square	Length of square
L	ℓ	ℓn	ℓs	Ds	K	ℓk

JIS

#### PO Spiral Pointed Taps

Size	Class	Code	Chamfer	L (mm)	ℓ (mm)	ℓn (mm)	ℓs (mm)	Ds (mm)	K (mm)	ℓk (mm)	No. of flutes	TYPE	MSRP
M13 × 1	P3	POR013M	5P	88	26	-	45	10.5	8	11	3	5	¥ 5,120*
M13 × 0.75	P3	POR013J	5P	88	14	-	45	10.5	8	11	3	6	¥ 6,550*
M13 × 0.5	P2	POQ013G	5P	88	12	-	45	10.5	8	11	3	6	¥ 6,550*
M14 × 2	P4	POS0140	5P	88	26	-	45	10.5	8	11	3	5	¥ 4,410
M14 × 2	P5	POT014Q	5P	88	26	-	45	10.5	8	11	3	5	¥ 4,410*
M14 × 1.5	P3	POR0140	5P	88	26	-	45	10.5	8	11	3	5	¥ 4,410
M14 × 1.5	P4	POS0140	5P	88	26	-	45	10.5	8	11	3	5	¥ 4,410*
M14 × 1.5	P5	POT0140	5P	88	26	-	45	10.5	8	11	3	5	¥ 4,410*
M14 × 1.25	P3	POR014N	5P	88	26	-	45	10.5	8	11	3	5	¥ 5,120*
M14 × 1	P3	POR014M	5P	88	26	-	45	10.5	8	11	3	5	¥ 5,120
M14 × 1	P4	POS014M	5P	88	26	-	45	10.5	8	11	3	5	¥ 5,120*
M14 × 0.75	P3	POR014J	5P	88	15	-	45	10.5	8	11	3	6	¥ 6,550*
M14 × 0.5	P2	POQ014G	5P	88	12	-	45	10.5	8	11	3	6	¥ 6,550*
M15 × 2	P4	POS015Q	5P	95	26	-	48	12.5	10	13	3	5	¥ 5,890*
M15 × 1.5	P3	POR0150	5P	95	26	-	48	12.5	10	13	3	5	¥ 5,890*
M15 × 1	P3	POR015M	5P	95	26	-	48	12.5	10	13	3	5	¥ 7,020*
M16 × 2	P4	POS016Q	5P	95	26	-	48	12.5	10	13	3	5	¥ 5,890*
M16 × 2	P5	POT016Q	5P	95	26	-	48	12.5	10	13	3	5	¥ 5,890*
M16 × 2	P6	POU016Q	5P	95	26	-	48	12.5	10	13	3	5	¥ 5,890*
M16 × 1.5	P3	POR0160	5P	95	26	-	48	12.5	10	13	3	5	¥ 5,890*
M16 × 1.5	P4	POS0160	5P	95	26	-	48	12.5	10	13	3	5	¥ 5,890*
M16 × 1.5	P5	POT0160	5P	95	26	-	48	12.5	10	13	3	5	¥ 5,890*
M16 × 1.25	P3	POR016N	5P	95	26	-	48	12.5	10	13	3	5	¥ 7,020*
M16 × 1	P3	POR016M	5P	95	26	-	48	12.5	10	13	3	5	¥ 7,020
M17 × 1.5	P4	POS0170	5P	100	33	-	51	14	11	14	3	5	¥ 7,870*
M17 × 1	P4	POS017M	5P	100	18	-	51	14	11	14	3	6	¥ 10,100*
M18 × 2.5	P4	POS018R	5P	100	33	-	51	14	11	14	3	5	¥ 7,870
M18 × 2.5	P5	POT018R	5P	100	33	-	51	14	11	14	3	5	¥ 7,870*
M18 × 2	P4	POS018Q	5P	100	33	-	51	14	11	14	3	5	¥ 7,870*
M18 × 1.5	P4	POS0180	5P	100	33	-	51	14	11	14	3	5	¥ 7,870*
M18 × 1.5	P5	POT0180	5P	100	33	-	51	14	11	14	3	5	¥ 7,870*
M18 × 1.25	P3	POR018N	5P	100	33	-	51	14	11	14	3	5	¥ 10,100*
M18 × 1	P3	POR018M	5P	100	18	-	51	14	11	14	3	6	¥ 10,100
M19 × 1.5	P4	POS0190	5P	105	33	-	50	15	12	15	3	7	¥ 10,700*
M19 × 1	P3	POR019M	5P	105	18	-	50	15	12	15	3	8	¥ 13,600*
M20 × 2.5	P4	POS020R	5P	105	33	-	50	15	12	15	3	7	¥ 10,700*
M20 × 2.5	P5	POT020R	5P	105	33	-	50	15	12	15	3	7	¥ 10,700*
M20 × 2	P4	POS020Q	5P	105	33	-	50	15	12	15	3	7	¥ 10,700*
M20 × 1.5	P4	POS0200	5P	105	33	-	50	15	12	15	3	7	¥ 10,700*
M20 × 1.5	P5	POT0200	5P	105	33	-	50	15	12	15	3	7	¥ 10,700*
M20 × 1	P3	POR020M	5P	105	10	-	50	15	12	15	3	0	¥ 13,600
M22 × 2.5	P4	POS022R	5P	115	33	-	55	17	13	16	3	7	¥ 13,700*
M22 × 2.5	P5	POT022R	5P	115	33	-	55	17	13	16	3	7	¥ 13,700*
M22 × 2	P4	POS022Q	5P	115	33	-	55	17	13	16	3	7	¥ 13,700*
M22 × 1.5	P4	POS0220	5P	115	33	-	55	17	13	16	3	7	¥ 13,700*
M22 × 1.5	P5	POT0220	5P	115	33	-	55	17	13	16	3	7	¥ 13,700*
M22 × 1	P3	POR022M	5P	115	19	-	55	17	13	16	3	8	¥ 17,700*
M24 × 3	P4	POS024S	5P	120	39	-	55	19	15	18	3	7	¥ 17,100*
M24 × 3	P5	POT024S	5P	120	39	-	55	19	15	18	3	7	¥ 17,100*

JIS  
3-15

Think threads with **YAMAWA**  
\* = Specified Distribution Items. Made to order products.  
For improvement, spec may change without advance notice.

Overall length	Thread length	Thread + Neck length	Shank length	Shank dia.	Size of square	Length of square
L	ℓ	ℓn	ℓs	Ds	K	ℓk

### 3

JIS

#### PO Spiral Pointed Taps

Size	Class	Code	Chamfer	L (mm)	ℓ (mm)	ℓn (mm)	ℓs (mm)	Ds (mm)	K (mm)	ℓk (mm)	No. of flutes	TYPE	MSRP
M24 × 3	P6	POU024S	5P	120	39	-	55	19	15	18	3	7	¥ 17,100*
M24 × 2	P4	POS0240	5P	120	39	-	55	19	15	18	3	7	¥ 17,100
M24 × 1.5	P4	POS0240	5P	120	39	-	55	19	15	18	3	7	¥ 17,100
M24 × 1.5	P5	POT0240	5P	120	39	-	55	19	15	18	3	7	¥ 17,100*
M24 × 1	P3	POR024M	5P	120	19	-	55	19	15	18	3	8	¥ 21,800*
M25 × 2	P4	POS025Q	5P	125	39	-	58	19	15	18	3	7	¥ 22,500*
M25 × 1.5	P4	POS0250	5P	125	39	-	58	19	15	18	3	7	¥ 22,500
M25 × 1	P3	POR025M	5P	125	20	-	58	19	15	18	3	8	¥ 26,700*
M26 × 3	P4	POS026S	5P	130	39	-	60	20	15	18	4	7	¥ 24,200*
M26 × 2	P4	POS026Q	5P	130	39	-	60	20	15	18	4	7	¥ 24,200*
M26 × 1.5	P4	POS0260	5P	130	39	-	60	20	15	18	4	7	¥ 24,200
M26 × 1	P3	POR026M	5P	130	20	-	60	20	15	18	4	8	¥ 29,900*
M27 × 3	P4	POS027S	5P	130	39	-	60	20	15	18	4	7	¥ 24,200*
M27 × 2	P4	POS027Q	5P	130	39	-	60	20	15	18	4	7	¥ 24,200*
M27 × 1.5	P4	POS0270	5P	130	39	-	60	20	15	18	4	7	¥ 24,200
M27 × 1	P3	POR027M	5P	130	20	-	60	20	15	18	4	8	¥ 29,900*
M28 × 2	P4	POS028Q	5P	135	46	-	62	23	17	20	4	7	¥ 30,900*
M28 × 1.5	P4	POS0280	5P	135	46	-	62	23	17	20	4	7	¥ 30,900*
M28 × 1	P3	POR028M	5P	135	20	-	62	23	17	20	4	8	¥ 38,600*
M30 × 3.5	P5	POT030T	5P	135	46	-	62	23	17	20	4	7	¥ 30,900*
M30 × 3	P4	POS030S	5P	135	46	-	62	23	17	20	4	7	¥ 30,900*
M30 × 2	P4	POS0300	5P	135	46	-	62	23	17	20	4	7	¥ 30,900
M30 × 1.5	P4	POS0300	5P	135	46	-	62	23	17	20	4	7	¥ 30,900
M30 × 1	P3	POR030M	5P	135	21	-	62	23	17	20	4	8	¥ 38,600*
M32 × 3	P4	POMS032S	5P	145	46	-	67	24	19	22	4	7	¥ 36,000*
M32 × 2	P4	POMS032Q	5P	145	46	-	67	24	19	22	4	7	¥ 36,000*
M32 × 1.5	P4	POMS0320	5P	145	46	-	67	24	19	22	4	7	¥ 36,000*
M33 × 3.5	P5	POMT033T	5P	145	46	-	67	25	19	22	4	7	¥ 36,000*
M33 × 3	P4	POMS033S	5P	145	46	-	67	25	19	22	4	7	¥ 36,000*
M33 × 2	P4	POMS033Q	5P	145	46	-	67	25	19	22	4	7	¥ 36,000*
M33 × 1.5	P4	POMS0330	5P	145	46	-	67	25	19	22	4	7	¥ 36,000*
M34 × 2	P4	POMS034Q	5P	155	52	-	71	28	21	24	4	7	¥ 41,700*
M34 × 1.5	P4	POMS0340	5P	155	26	-	71	28	21	24	4	8	¥ 41,700*
M35 × 2	P4	POMS035Q	5P	155	52	-	71	28	21	24	4	7	¥ 41,700*
M35 × 1.5	P4	POMS0350	5P	155	26	-	71	28	21	24	4	8	¥ 41,700*
M36 × 4	P5	POMT036U	5P	155	52	-	71	28	21	24	4	7	¥ 41,700*
M36 × 3	P4	POMS036S	5P	155	52	-	71	28	21	24	4	7	¥ 41,700*
M36 × 2	P4	POMS036Q	5P	155	52	-	71	28	21	24	4	7	¥ 41,700*
M36 × 1.5	P4	POMS0360	5P	155	26	-	71	28	21	24	4	8	¥ 41,700*
M38 × 2	P4	POMS038Q	5P	165	52	-	76	30	23	26	4	7	¥ 47,800*
M38 × 1.5	P4	POMS0380	5P	165	26	-	76	30	23	26	4	8	¥ 47,800*
M39 × 4	P5	POMT039U	5P	165	52	-	76	30	23	26	4	7	¥ 47,800*
M39 × 3	P4	POMS039S	5P	165	52	-	76	30	23	26	4	7	¥ 47,800*
M39 × 2	P4	POMS039Q	5P	165	52	-	76	30	23	26	4	7	¥ 47,800*
M39 × 1.5	P4	POMS0390	5P	165	26	-	76	30	23	26	4	8	¥ 47,800*
M40 × 3	P4	POMS040S	5P	175	59	-	81	32	26	30	4	7	¥ 58,100*
M40 × 2	P4	POMS040Q	5P	175	59	-	81	32	26	30	4	7	¥ 58,100*
M40 × 1.5	P4	POMS0400	5P	175	27	-	81	32	26	30	4	8	¥ 58,100*
M42 × 4.5	P5	POMT042V	5P	175	59	-	81	32	26	30	4	7	¥ 58,100*
M42 × 3	P4	POMS042S	5P	175	59	-	81	32	26	30	4	7	¥ 58,100*

JIS  
3-16

Think threads with **YAMAWA**  
\* = Specified Distribution Items. Made to order products.  
For improvement, spec may change without advance notice.

### 3 Spiral Pointed Tap Series for through hole

Overall length	Thread length	Thread + Neck length	Shank length	Shank dia.	Size of square	Length of square
L	ℓ	ℓn	ℓs	Ds	K	ℓk

JIS

#### PO Spiral Pointed Taps

Size	Class	Code	Chamfer	L (mm)	ℓ (mm)	ℓn (mm)	ℓs (mm)	Ds (mm)	K (mm)	ℓk (mm)	No. of flutes	TYPE	MSRP
M42 × 2	P4	POMS042Q	5P	175	59	-	81	32	26	30	4	7	¥ 58,100*
M42 × 1.5	P4	POMS042O	5P	175	27	-	81	32	26	30	4	8	¥ 58,100*
M45 × 4.5	P5	POMT045V	5P	180	59	-	83	35	26	30	4	7	¥ 67,300*
M45 × 3	P4	POMS045S	5P	180	59	-	83	35	26	30	4	7	¥ 67,300*
M45 × 2	P4	POMS045Q	5P	180	59	-	83	35	26	30	4	7	¥ 67,300*
M45 × 1.5	P4	POMS045O	5P	180	27	-	83	35	26	30	4	8	¥ 67,300*
M48 × 5	P5	POMT048W	5P	185	65	-	85	38	29	32	4	7	¥ 84,100*
M48 × 3	P4	POMS048S	5P	185	65	-	85	38	29	32	4	7	¥ 84,100*
M48 × 2	P4	POMS048Q	5P	185	65	-	85	38	29	32	4	7	¥ 84,100*
M48 × 1.5	P4	POMS048O	5P	185	28	-	85	38	29	32	4	8	¥ 84,100*
M50 × 1.5	P4	POS050O	5P	145	45	-	81	40	32	35	4	7	¥ 91,400*
For Unified Threads													
No.0-80UNF	P1	POPUN0B	5P	36	6.3	-	24	3	2.5	5	2	2	¥ 3,200*
No.1-64UNC	P1	POPUN1D	5P	42	7.2	-	27	3	2.5	5	2	2	¥ 3,200*
No.1-72UNF	P1	POPUN1C	5P	42	7.2	-	27	3	2.5	5	2	2	¥ 3,200*
No.2-56UNC	P1	POPUN2E	5P	42	8.1	12	27	3	2.5	5	3	3	¥ 2,250
No.2-64UNF	P1	POPUN2D	5P	42	8.1	12	27	3	2.5	5	3	3	¥ 2,250*
No.3-48UNC	P1	POPUN3F	5P	46	8.1	14	29	3	2.5	5	3	3	¥ 1,900*
No.3-56UNF	P1	POPUN3E	5P	46	8.1	14	29	3	2.5	5	3	3	¥ 1,900*
No.4-40UNC	P2	POQUN4H	5P	46	9	14	25	4	3.2	6	3	3	¥ 1,450
No.4-48UNF	P1	POPUN4F	5P	46	9	14	25	4	3.2	6	3	3	¥ 1,450*
No.5-40UNC	P2	POQUN5H	5P	52	11	16	28	5	4	7	3	3	¥ 1,350*
No.5-44UNF	P1	POPUN5G	5P	52	11	16	28	5	4	7	3	3	¥ 1,350*
No.6-32UNC	P2	POQUN6J	5P	52	11	17	27	5	4	7	3	3	¥ 1,350*
No.6-40UNF	P2	POQUN6H	5P	52	11	17	27	5	4	7	3	3	¥ 1,350*
No.8-32UNC	P2	POQUN8J	5P	60	13	22	31	5.5	4.5	7	3	3	¥ 1,360*
No.8-36UNF	P2	POQUN8I	5P	60	13	22	31	5.5	4.5	7	3	3	¥ 1,360*
No.10-24UNC	P2	POQUNAM	5P	60	13	22	32	5.5	4.5	7	3	3	¥ 1,360
No.10-32UNF	P2	POQUNAJ	5P	60	13	22	32	5.5	4.5	7	3	3	¥ 1,360
No.12-24UNC	P2	POQUNCM	5P	62	15	26	32	6	4.5	7	3	3	¥ 1,460*
No.12-28UNF	P2	POQUNCK	5P	62	15	26	32	6	4.5	7	3	3	¥ 1,460*
1/4-20UNC	P2	POQU04N	5P	62	15	26	33	6	4.5	7	3	3	¥ 1,460
1/4-28UNF	P2	POQU04K	5P	62	15	26	33	6	4.5	7	3	3	¥ 1,460
1/4-32UNEF	P2	POQU04J	5P	62	15	26	33	6	4.5	7	3	3	¥ 2,170*
5/16-18UNC	P3	PORU05O	5P	70	19	-	36	6.2	5	8	3	5	¥ 2,060
5/16-24UNF	P2	POQU05M	5P	70	19	-	36	6.2	5	8	3	5	¥ 2,060
5/16-32UNEF	P2	POQU05J	5P	70	19	-	36	6.2	5	8	3	5	¥ 2,870*
3/8-16UNC	P3	PORU06P	5P	75	23	-	38	7	5.5	8	3	5	¥ 2,640
3/8-24UNF	P2	POQU06M	5P	75	23	-	38	7	5.5	8	3	5	¥ 2,640
3/8-32UNEF	P2	POQU06J	5P	75	13	-	38	7	5.5	8	3	6	¥ 3,220*
7/16-14UNC	P3	PORU07Q	5P	82	26	-	42	8.5	6.5	9	3	5	¥ 3,720*
7/16-20UNF	P3	PORU07N	5P	82	26	-	42	8.5	6.5	9	3	5	¥ 3,720*
7/16-28UNEF	P2	POQU07K	5P	82	26	-	42	8.5	6.5	9	3	5	¥ 4,850*
1/2-13UNC	P3	PORU08R	5P	88	26	-	45	10.5	8	11	3	5	¥ 3,950
1/2-20UNF	P3	PORU08N	5P	88	26	-	45	10.5	8	11	3	5	¥ 3,950
1/2-28UNEF	P2	POQU08K	5P	88	26	-	45	10.5	8	11	3	5	¥ 5,830*
9/16-12UNC	P3	PORU09S	5P	95	26	-	48	12.5	10	13	3	5	¥ 5,890*
9/16-18UNF	P3	PORU09O	5P	95	26	-	48	12.5	10	13	3	5	¥ 5,890*

1 Spiral Fluted Taps (for blind hole)

2 Spiral Fluted Taps (for through hole)

3 Spiral Pointed Taps (for through hole)

4 Hand Taps

5 Cemented Carbide Taps

6 Roll Taps

7 Special Thread Taps (Simple Inspection Tools)

8 Pipe Taps

9 Thread Mills

10 Dies

11 Center Drills Centering Tools

Overall length	Thread length	Thread + Neck length	Shank length	Shank dia.	Size of square	Length of square
L	ℓ	ℓn	ℓs	Ds	K	ℓk

### 3

JIS

#### PO Spiral Pointed Taps

Size	Class	Code	Chamfer	L (mm)	ℓ (mm)	ℓn (mm)	ℓs (mm)	Ds (mm)	K (mm)	ℓk (mm)	No. of flutes	TYPE	MSRP
5/8-11UNC	P3	PORU10U	5P	95	26	-	48	12.5	10	13	3	5	¥ 5,890*
5/8-18UNF	P3	PORU10O	5P	95	26	-	48	12.5	10	13	3	5	¥ 5,890*
5/8-24UNEF	P3	PORU10M	5P	95	26	-	48	12.5	10	13	3	5	¥ 8,430*
3/4-10UNC	P4	POSU12V	5P	105	33	-	50	15	12	15	3	7	¥ 10,700*
3/4-16UNF	P3	PORU12P	5P	105	33	-	50	15	12	15	3	7	¥ 10,700
3/4-20UNEF	P3	PORU12N	5P	105	33	-	50	15	12	15	3	7	¥ 13,600*
7/8-9UNC	P4	POSU14W	5P	115	33	-	55	17	13	16	3	7	¥ 15,100*
7/8-14UNF	P3	PORU14Q	5P	115	33	-	55	17	13	16	3	7	¥ 15,100*
1-8UNC	P4	POSU16X	5P	125	39	-	58	19	15	18	3	7	¥ 22,500*
1-12UNF	P4	POSU16S	5P	125	39	-	58	19	15	18	3	7	¥ 22,500*
1-14UNS	P4	POSU16O	5P	125	39	-	58	19	15	18	3	7	¥ 29,900*
1 1/8-7UNC	P4	POSU18Y	5P	135	46	-	62	23	17	20	4	7	¥ 30,900*
1 1/8-12UNF	P4	POSU18S	5P	135	46	-	62	23	17	20	4	7	¥ 30,900*
1 1/4-7UNC	P4	POMSU20Y	5P	145	46	-	67	24	19	22	4	7	¥ 36,000*
1 1/4-12UNF	P4	POMSU20S	5P	145	46	-	67	24	19	22	4	7	¥ 36,000*
1 3/8-6UNC	P5	POMTU22Z	5P	155	52	-	71	28	21	24	4	7	¥ 41,700*
1 3/8-12UNF	P4	POMSU22S	5P	155	52	-	71	28	21	24	4	7	¥ 41,700*
1 1/2-6UNC	P5	POMTU24Z	5P	165	52	-	76	30	23	26	4	7	¥ 59,700*
1 1/2-12UNF	P4	POMSU24S	5P	165	52	-	76	30	23	26	4	7	¥ 59,700*
For Whitworth Threads													
1/8W40	P2	POQW02H	5P	52	11	16	28	5	4	7	3	3	¥ 1,680*
5/32W32	P2	POQW2HJ	5P	52	11	17	29	5	4	7	3	3	¥ 1,350*
3/16W24	P2	POQW03M	5P	60	13	21	33	5.5	4.5	7	3	3	¥ 1,360
7/32W24	P2	POQW3HM	5P	62	15	26	33	6	4.5	7	3	3	¥ 1,460*
1/4W20	P3	PORW04N	5P	62	15	26	33	6	4.5	7	3	3	¥ 1,460
5/16W18	P3	PORW05O	5P	70	19	-	36	6.2	5	8	3	5	¥ 2,060
3/8W16	P3	PORW06P	5P	75	23	-	38	7	5.5	8	3	5	¥ 2,640
7/16W14	P3	PORW07Q	5P	82	26	-	42	8.5	6.5	9	3	5	¥ 3,720*
1/2W12	P3	PORW08S	5P	88	26	-	45	10.5	8	11	3	5	¥ 3,950
9/16W12	P3	PORW09S	5P	95	26	-	48	12.5	10	13	3	5	¥ 5,890*
5/8W11	P3	PORW10U	5P	95	26	-	48	12.5	10	13	3	5	¥ 5,890
3/4W10	P4	POSW12V	5P	105	33	-	50	15	12	15	3	7	¥ 10,700
7/8W9	P4	POSW14W	5P	115	33	-	55	17	13	16	3	7	¥ 15,100*
1 W8	P4	POSW16X	5P	125	39	-	58	19	15	18	3	7	¥ 22,500*
1 1/8W7	P4	POSW18Y	5P	135	46	-	62	23	17	20	4	7	¥ 30,900*
1 1/4W7	P4	POMSW20Y	5P	145	46	-	67	24	19	22	4	7	¥ 36,000*
1 3/8W6	P5	POMTW22Z	5P	155	52	-	71	28	21	24	4	7	¥ 41,700*
1 1/2W6	P5	POMTW24Z	5P	165	52	-	76	30	23	26	4	7	¥ 59,700*
2 W4.5	P5	POTW329	5P	195	70	-	85	40	32	35	4	7	¥ 131,000*
For Screw Threads used on Sewing Machines													
3/32SM56	P1	POPS06E	5P	46	8.1	14	29	3	2.5	5	3	3	¥ 2,290*
1/8SM40	P2	POQS08H	5P	52	11	16	28	5	4	7	3	3	¥ 1,680*
1/8SM44	P2	POQS08G	5P	52	11	16	28	5	4	7	3	3	¥ 1,680*
9/64SM40	P2	POQS09H	5P	52	11	16	29	5	4	7	3	3	¥ 1,680*
11/64SM40	P2	POQS11H	5P	60	13	21	33	5.5	4.5	7	3	3	¥ 1,640*
3/16SM28	P2	POQS12K	5P	60	13	21	33	5.5	4.5	7	3	3	¥ 1,640*
3/16SM32	P2	POQS12J	5P	60	13	21	33	5.5	4.5	7	3	3	¥ 1,640*
7/32SM32	P2	POQS14J	5P	62	15	26	33	6	4.5	7	3	3	¥ 1,760*

1 Spiral Fluted Taps (for blind hole)

2 Spiral Fluted Taps (for through hole)

3 Spiral Pointed Taps (for through hole)

4 Hand Taps

5 Cemented Carbide Taps

6 Roll Taps

7 Special Thread Taps (Simple Inspection Tools)

8 Pipe Taps

9 Thread Mills

10 Dies

11 Center Dr

### 3 Spiral Pointed Tap Series for through hole

Overall length	Thread length	Thread + neck length	Shank length	Shank dia.	Size of square	Length of square
L	ℓ	ℓn	ℓs	Ds	K	ℓk

JIS

#### PO Spiral Pointed Taps

Size	Class	Code	Chamfer	L (mm)	ℓ (mm)	ℓn (mm)	ℓs (mm)	Ds (mm)	K (mm)	ℓk (mm)	No. of flutes	TYPE	MSRP
<b>15/64SM28</b>	P2	P0QS15K	5P	62	15	26	33	6	4.5	7	3	3	¥ 1,760*
<b>1/4SM24</b>	P2	P0QS16M	5P	62	15	26	33	6	4.5	7	3	3	¥ 1,760*
<b>1/4SM40</b>	P2	P0QS16H	5P	62	8.6	26	33	6	4.5	7	3	4	¥ 2,530*

1 Spiral Fluted Taps (for blind hole)

2 Spiral Fluted Taps (for through hole)

3 Spiral Pointed Taps (for through hole)

4 Hand Taps

5 Cemented Carbide Taps

6 Roll Taps

7 Special Thread Taps (Simple Inspection Tools)

8 Pipe Taps

9 Thread Mills

10 Dies

11 Center Drills Centering Tools

JIS



\* = Specified Distribution Items. Made to order products.  
For improvement, spec may change without advance notice.